

Summerraire

CENTRAL VENTILATION SYSTEMS

MODEL

SHRV 600 FD

Commercial
Heat Recovery
Ventilator

APPLICATION WARNING!!

It is always important to assess how the operation of any Heat Recovery Ventilator (HRV), may interact with vented combustion equipment. (i.e. Gas Furnaces, Oil Furnaces, Wood Stoves, etc.)

NEVER install an HRV in a situation where its normal operation, lack of operation or partial failure may result in the backdrafting or improper functioning of vented combustion equipment!

INSTALLATION and OPERATION MANUAL

INTRODUCTION:

The SHRV 600 FD Heat Recovery Ventilator (HRV) is designed for large residential, commercial and industrial applications to provide fresh air into a building while exhausting an equal amount of stale air. During the winter months the incoming cold fresh air is warmed by utilizing the heat recovered from the stale air before it is exhausted to the outdoors. During the summer months when the indoor space is air conditioned, the heat recovery ventilator will cool the incoming air with the air that is being exhausted.

The Model 600 is equipped with an electronically controlled fan defrost system to remove frost that collects on the warm air side of the heat transfer surfaces of the heat exchanger element. When the outside air temperature drops below -3 degrees Celsius (25°F) a defrost timer is activated which provides for an automatic defrost cycle approximately every 23 minutes. During the automatic defrost cycle the fresh air supply fan is shut off for approximately 5 minutes while the exhaust fan continues to operate. This allows warm inside air to flow over the heat exchanger element melting any frost accumulations. After the defrost period the fresh air supply fan automatically returns to the normal speed and fresh outside air continues to be drawn into the building. Any water from the melted frost collects in the bottom drip pans and drains out through the bottom drain connection. The defrost cycle repeats automatically until the air temperature rises above -3 degrees Celsius (26°F).

The defrost control has a self-test feature which indicates the defrost cycle whenever the unit is started or there is a power interruption. The fan defrost operates in the defrost mode for the 5 minute cycle time and then returns to normal operation. The LED light on the control panel of the HRV is on during this defrost period which indicates that the defrost cycle and control are functioning properly.

LOCATION AND MOUNTING OF THE MODEL 600 HRV:

The HRV must be located in a heated space where the surrounding air temperature does not fall below the freezing point. The defrost air temperature must be above 60°F for proper defrost operation. If the air temperature is too low, the defrost time may need to be increased. The unit must be mounted level to obtain proper drainage of water from the heat exchange element and the drip pans. The warranty will be void if these conditions are not met.

Typically, the HRV is positioned close to an outside wall or the roof to simplify the connections and keep the length of insulated ducting required for the fresh air intake to a minimum.

A minimum clearance of 90 cm (36 inches) in front of the HRV is recommended to service the heat exchanger elements and the filters. The four rubber straps supplied are intended to be used to hang the HRV from floor or ceiling joists. The straps should be attached to the top end corners of the HRV case. Securely fasten the other end of the straps with large head screws or bolts. The rubber straps are designed to reduce the possibility of any fan sound being transmitted to the floor joists or alternately preventing any vibration in the floor from being transmitted to the ducting. The HRV may also be mounted on an equipment platform providing the drain hoses are clear and there is sufficient space to open the doors for servicing.

Install the drain pan in the bottom of the HRV so the drain connections protrude through the holes provided. See Figure 1 for installation of the drain pans and the drain connections. Use drain hoses with hose clamps to connect the drain pan outlets to a floor drain or standpipe. Make sure the drain line slopes down to the outlet and if this is not possible a condensate pump will be required for positive removal of the water. Protect the drain line from freezing.

Figure 1
Model 600
FRONT VIEW SCHEMATIC

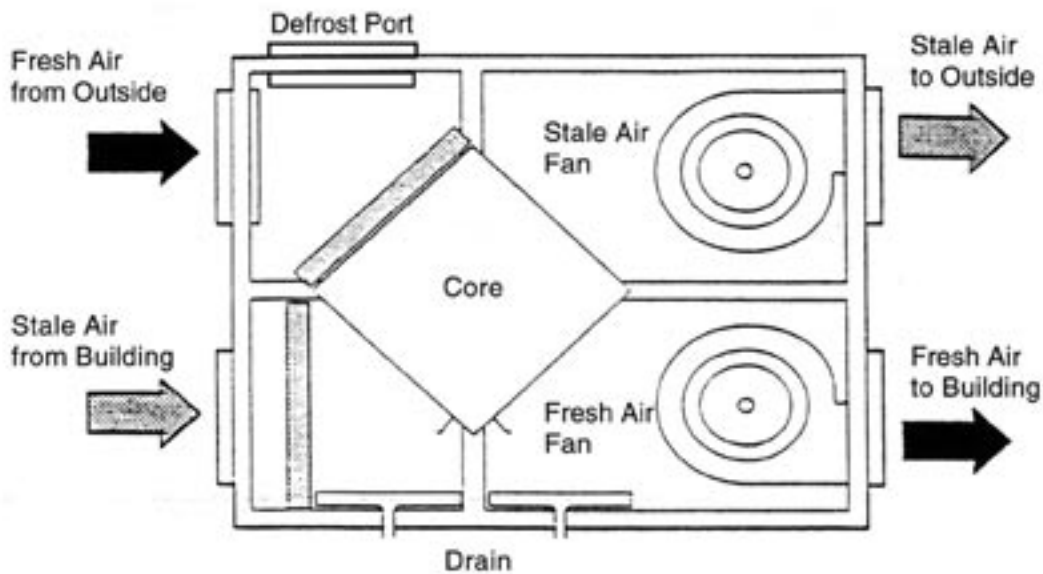

THE DUCTWORK SYSTEM:

A well designed ducting system will allow the HRV to operate at its maximum efficiency. Avoid the use of undersized ducting and sharp radius bends or tees which can significantly increase the system pressure drop and reduce the air flows. The four ports on the Model 600 are designed to accept 8" X 14" hard duct for attachment to the ductwork system. Flexible duct collars should be installed at all inlets/outlets on the unit to insure sound/vibration isolation from the duct system.

NOTE: Fully insulated ducting with an integral vapour barrier must be used in all unheated areas to prevent condensation on the ducting and to reduce heat loss to the unheated air.

A. OUTSIDE WEATHERHOODS

The outside weatherhood connections must contain mesh screens with at least 6 mm (1/4") spacing to prevent foreign objects entering the system ducting. A smaller mesh must not be used as it will be susceptible to plugging. Do not use flappers or dampers at the vents that will restrict air flow.

The preferred location of the outside weatherhood is:

- not less than 2 metres (10 feet) apart.
- at least 46 cm (18") above ground level. In areas that receive very large snowfalls a higher location is recommended.
- away from sources of contamination such as automobile exhaust fumes, gas meters, garbage cans, roof exhausts, etc.
- avoid direct exposure to prevailing winds which can create extra static pressure on the fans.
- locate roof vents away from walls and select ventilator designs that are not affected by wind.

The outside perimeter of the weatherhood must be caulked to prevent leakage into the building. Roof vents must have adequate curb height for water protection and be sealed to the ducting.

B. DUCTING FROM THE WEATHERHOOD TO THE HRV:

Galvanized sheet metal ducting with an 8" X 14" or equivalent cross section with an integral single piece vapour barrier should be used to connect the HRV to the weatherhoods. All ducting must meet UL Class 1 fire rating. A minimum RSI insulation value of 0.75 (R4) is recommended. The fresh air ducting must be well sealed to prevent air leaks. A good bead of high quality caulking (preferably acoustical sealant) and taping with a high quality aluminum foil tape is recommended to seal the duct to both the HRV and the weatherhood.

C. STALE AIR RETURN SYSTEM:

The stale air return system is used to draw air from the points in the building where the worst air quality problems normally occur. Balancing dampers and/or adjustable grilles are recommended on all return air lines which are used during installation to help balance the "draw" from different areas of the building.

A damper located just prior to the HRV is required to balance the stale air exhausted with the fresh air supply entering the building.

Return air suction points should be located at the opposite side of the room to the fresh air inlet. The inlets may be located in the ceiling or high on the walls and fitted with inlet grilles. Air temperatures at the inlets must not exceed 65°C (150°F) The wall cavities may be used as ducting provided they are lined with galvanized sheet metal.

D. FRESH AIR SUPPLY SYSTEM:

Do not connect the fresh air supply ductwork directly to the return or supply side of a forced air furnace because the suction or negative pressure developed by the furnace fan may create an air imbalance in the system. This imbalance can cause air to be drawn through the HRV in excess of ventilation requirements while the furnace is operating.

Some or all of the fresh air from the HRV may be discharged towards an inlet grille installed in the cold air return duct of the furnace provided it is sized to handle the air flow required. The HRV fresh air supply outlet should be approximately 30 cm. (12 in.) from the inlet grille of the furnace return air duct.

NOTE: The grille in the cold air return must be at least 2 metres (6 ft.) straight line from a fossil-fueled furnace or as specified by local regulations.

Supply air grilles may be ceiling or high wall mounted. Avoid locating incoming fresh air grilles that could cause a direct draft on the occupants as the incoming air will be below the room temperature. Reheat duct heater can be installed to improve room comfort.

E. DUCTS AND GRILLES:

To minimize pressure drop and noise, galvanized metal ducts sized for 1100 fpm. are recommended. Keep ducting as short as possible and use a minimum of elbows and tees. Connecting sections and shorter runs may be flexible ducting one size larger than the metal duct. Use flexible ducting at the HRV to avoid noise transmission.

All duct joints must be secured with screws or rivets and sealed with aluminum duct tape to prevent leakage.

F. ELECTRICAL CONNECTIONS:

A licensed electrician should make all the electrical connections. The HRV must be properly grounded and a separate 15 amp, 120 volt circuit is recommended. See Figure 2 for recommended electrical connections.

WARNING: To prevent electrical shock when servicing the HRV make certain the hot line (black) of the electrical supply is connected to the internal safety shut-off switch. This can be checked by using a voltmeter or test light to verify there is no voltage reading in the unit after the safety shut off switch when the doors are open. Always check that the HRV is properly grounded.

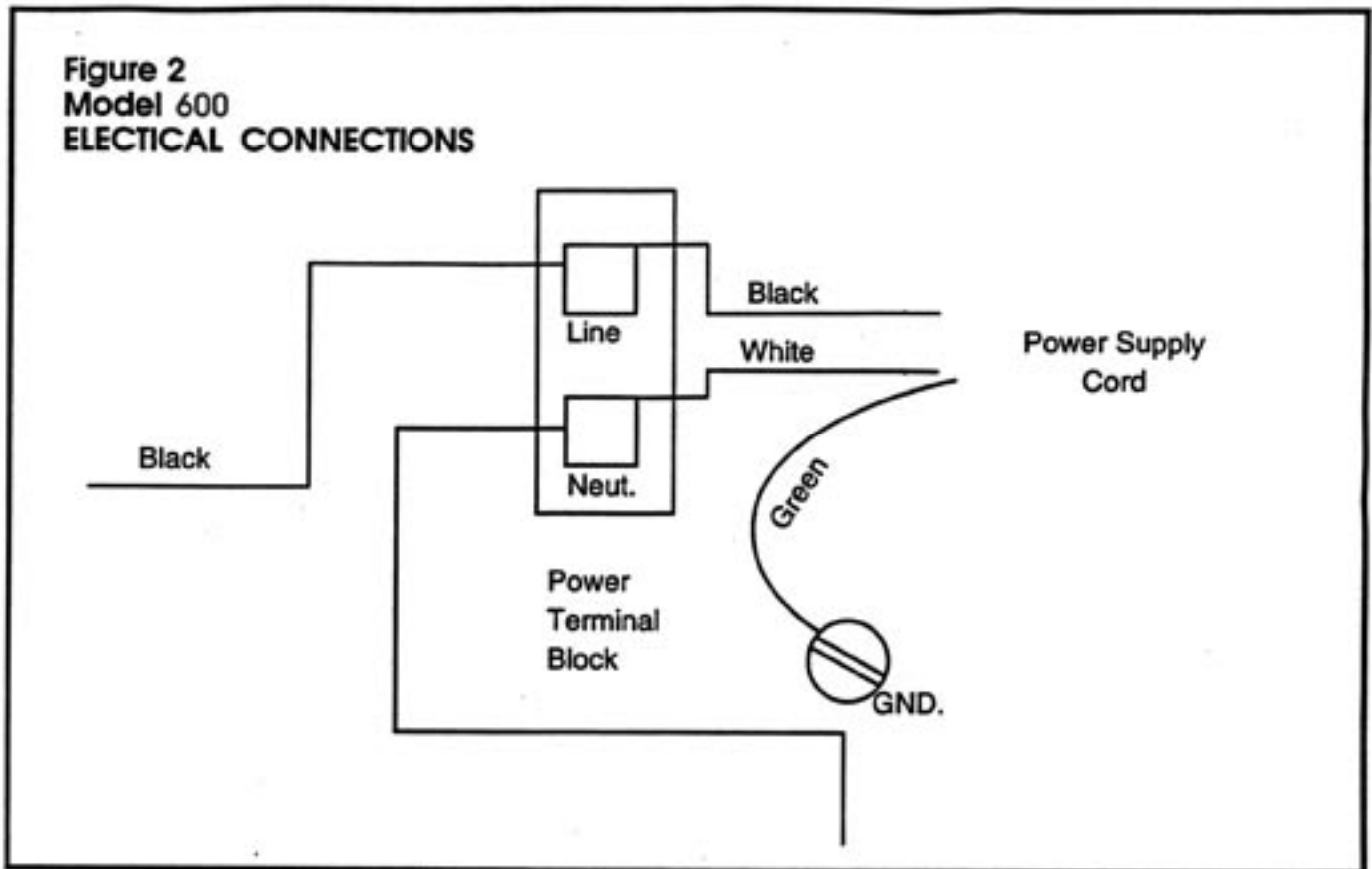

G. HEAT EXCHANGE AIR FLOW BALANCING:

To obtain maximum efficiency from the HRV the exhaust air flow must be balanced with the entering fresh air flow. An excessive positive pressure may cause moist air to migrate into the wall cavity where it can condense on the cold outside walls and collect as water. An excessive negative pressure may cause backdrafts from vented combustion equipment such as a furnace, fireplace or water heater and cause drafts near outside windows and doors.

Balancing Procedure:

- A. To balance the air flow requires an accurate flow measure of the fresh entering air and the exhaust stale air. The air flows can be measured with a calibrated measuring instrument such as a flow orifice or by measuring the air velocity across the duct with a pitot tube or hot wire anemometer. The flow measurements should be made in a straight section 10 duct diameters from an elbow or restriction.
- B. Prior to balancing make sure the following has been done:
 - 1. All duct joints have been sealed.
 - 2. All of the HRV components are in place and operating properly.
 - 3. Balancing dampers are fully open.
 - 4. Speed control on the HRV is set in high.
- C. Air flows in branch lines to specific areas of the building should be adjusted prior to balancing. Check for air flow at the grilles with a smoke pencil.
- D. After the first air flow readings are complete, only adjust the higher air flow side until both air flows are equal.

SHRV 600 FD WIRING DIAGRAM

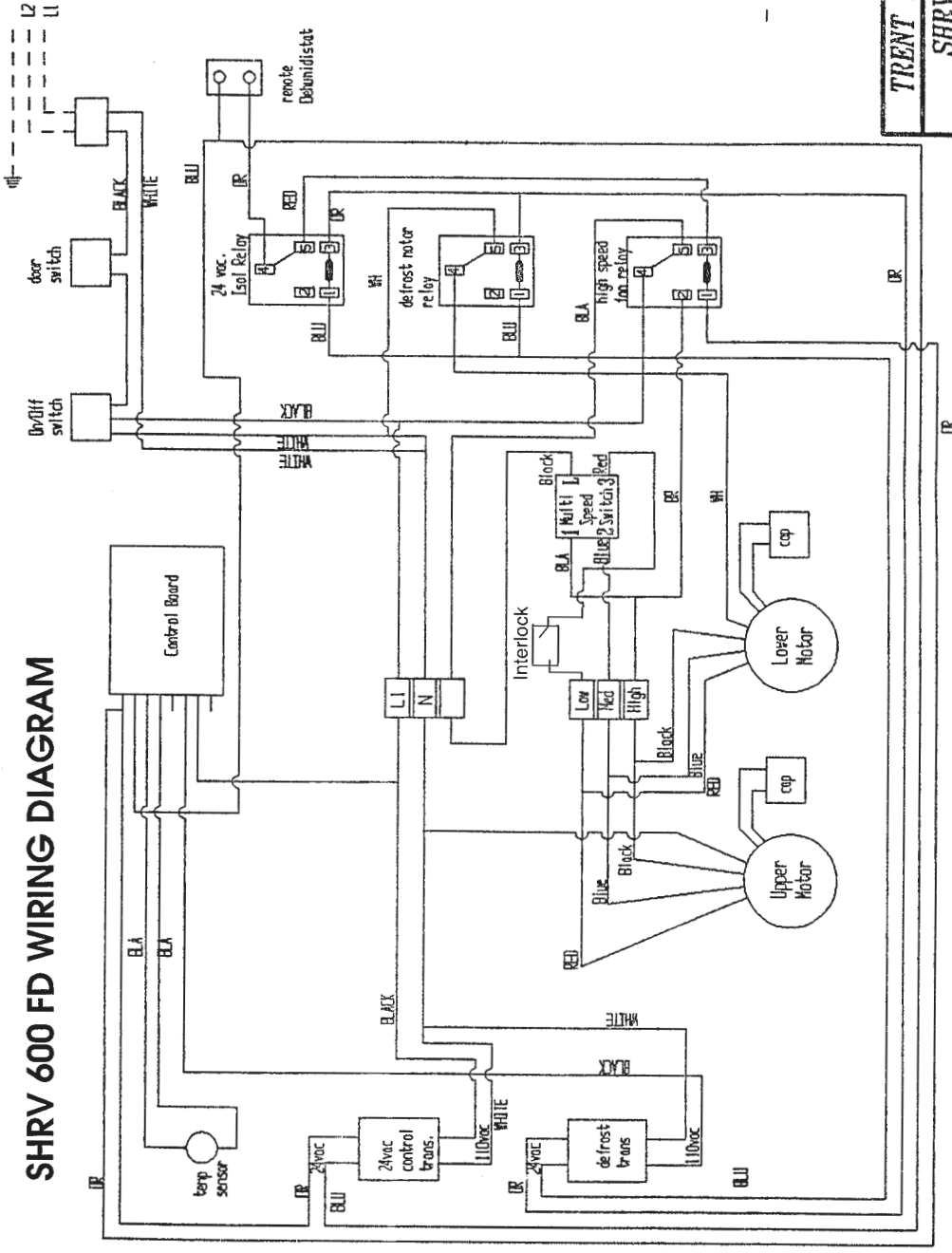

--- Field Wiring

Note: All wiring to be min. 18 ga. type AWG, min. volt rating 600vac., min. 105 deg. C.

TRENT METALS LIMITED
SHRV Commercial
Part: Wiring Diagram
Used On: SHRV600FD
Date: 4/11/01
Scale: n.t.s.
Drwg: V600FD