



Built Better to Last Longer

INSTALLATION INSTRUCTIONS AND HOMEOWNER'S MANUAL

**SLO80CV-DV SERIES
LO-BOY
OIL FIRED FURNACE**

INSTALLER/ SERVICE TECHNICIAN

USE THE INFORMATION IN THIS MANUAL FOR THE INSTALLATION/ SERVICING OF THE FURNACE AND KEEP THE DOCUMENT NEAR THE UNIT FOR FUTURE REFERENCE.

HOMEOWNER

PLEASE KEEP THIS MANUAL NEAR THE FURNACE FOR FUTURE REFERENCE.

**DO NOT TAMPER WITH THIS UNIT OR IT'S CONTROLS
CALL A QUALIFIED SERVICE TECHNICIAN.**

**DO NOT USE GASOLINE, CRANKCASE OIL, OR ANY OIL CONTAINING GASOLINE;
NEVER BURN GARBAGE OR PAPER IN THE HEATING SYSTEM, AND NEVER LEAVE
PAPER OR RAGS AROUND THE APPLIANCE.**



Manufactured by
Summerraire Manufacturing
Division of Trent Metals Limited
Peterborough, Ontario
Canada



ENERGY
PERFORMANCE
VERIFIED
RENDEMENT
ENERGETIQUE
VERIFIE

TABLE OF CONTENTS

1	SAFETY REGULATIONS.....	3
1.1	Safety labeling and warning signs	3
1.2	Important Information	3
1.3	Detection Systems	3
2	INSTALLATION	3
2.1	Positioning the furnace.....	4
2.2	Configurations	4
2.3	Electrical System	5
2.4	Installation of the thermostat	5
2.5	Installation of the burner	5
2.6	Venting	5
2.7	Blocked Flue shut off device (BFS) for chimney venting	5
2.8	Combustion air supply and ventilation	7
2.9	Oil Tank	7
2.10	Ducting.....	8
2.11	Supply air adjustments (3 speed motors).....	8
2.12	Supply air adjustments (ECM variable speed motors).....	8
2.13	Installation of accessories	8
3	OPERATION	9
3.1	Start-up.....	9
3.2	Operating sequence oil heating mode	9
3.3	Check and adjustments.....	9
4	MAINTENANCE	11
4.1	Cleaning the heat exchanger	11
4.2	Cleaning the blocked Flue shut-off device(BFS).....	11
4.3	Cleaning the burner head	11
4.4	Replacing the nozzle	12
4.5	Replacing the oil filter	12
4.6	Replacing the air filter	12
	WIRING DIAGRAMS	15
	SLOCV/DVPR	15
	SLO80CV/DVPB	16
	SLO80CV/DVER	17
	SLO80CV/DVEB	18
	REPLACEMENT PARTS	19
	REPLACEMENT PARTS DIAGRAM	19
	REPLACEMENT PARTS LIST	20
	WARRANTY	21

SAFETY REGULATIONS

SAFETY LABELING AND WARNING SIGNS

The words DANGER, WARNING AND CAUTION are used to identify the levels of seriousness of certain hazards. It is important that you understand their meaning. You will notice these words in the manual as follows:

! DANGER

Immediate hazards that WILL result in death, serious bodily injury and/or property damage.

! WARNING

Hazards or unsafe practices that CAN result in death, body injury and/or property damage.

! WARNING

Non-observance of the safety regulations outlined in this manual will potentially lead to consequences resulting in death, serious bodily injury and/or property damage.

NOTICE

Always keep the oil supply valve shut off if the burner is shut down for an extended period of time.

CAUTION

Hazards or unsafe practice that CAN result in bodily injury and/or property damage.

CAUTION

Never burn garbage or paper in the heating system and never leave paper or rags around the heating system.

CAUTION

Do not start the burner unless the blower access door is secured in place.

CAUTION

**DO NOT USE GASOLINE, CRANKCASE OIL, OR ANY OIL CONTAINING GASOLINE;
NEVER BURN GARBAGE OR PAPER IN THE HEATING SYSTEM, AND NEVER LEAVE PAPER OR RAGS AROUND THE APPLIANCE.**

IMPORTANT INFORMATION

- a) It is the homeowner's responsibility to engage a qualified technician and where required by the local Authority, a licensed technician for the installation, start-up and subsequent servicing of this furnace.
- b) Do not use this furnace if any part of it was under water. Call a qualified technician immediately to assess the damage and to replace all critical parts that were in contact with water.
- c) Do not store gasoline or any other flammable substance such as paper, carton, etc. near the furnace.
- d) This furnace is designed for use with #1 or #2 heating oil only. The use of gasoline, motor oil or any other oil containing gasoline is prohibited.
- e) Never block or otherwise obstruct the filter and/or return air openings.
- f) Ask the technician installing your furnace to show and explain to you the following items
 - i)The main disconnect switch
 - ii)The shut off valve on the oil tank
 - iii)The air filter and how to check it (check monthly and clean or replace if necessary.)
- g) Before calling for service, be sure to have the information page of your manual close by in order to be able to provide the contractor with the required information, such as the model and serial numbers of the furnace.

! WARNING

Installation and repairs performed by unqualified persons can result in hazards to them and to others. Installations must conform to local codes (or in the absence of same) to codes of the country having jurisdiction.

The information contained in this manual is intended for use by a qualified technician familiar with safety procedures and who is equipped with the proper tools and test instruments. Failure to carefully read and follow all instructions in this manual can result in death, bodily injury and/or property damage.

DETECTION SYSTEM

It is recommended that carbon monoxide detectors be installed wherever oil or gas fired heaters are used. Carbon Monoxide can cause bodily harm or death. For this reason agency approved carbon monoxide detectors should be installed in your residence and properly maintained to warn of dangerously high carbon monoxide levels.

INSTALLATION

All local codes and national code requirements governing the installation of oil burning equipment, wiring and flue connection **MUST** be followed. Some of the codes that may apply are:

- CSAB139:** Installation code for oil burning equipment.
ANSI/NFPA 31: Installation of oil burning equipment.
ANSI/NFPA 90B: Warm air heating and air conditioning systems.

ANSI/NFPA 211: Chimneys, Fireplaces, Vents and solid fuel burning appliances.

ANSI/NFPA 70: National Electrical Code.

CSA C22.1 or CSA C22.10: Canadian Electrical code

Only the most recent issue of these codes may be used. To ensure all components are in good condition carefully inspect all components prior to assembly. Components should be as follows:

For Chimney vent applications

FSSLO80	Furnace section	1
BPSLOB	Beckett Burner	1
BPSLOCVR	or Riello Burner	1
BFSSHO	Blocked Flue Switch	1

For Direct vent applications:

FSSLO80	Furnace section	1
BPSLOB	Beckett Burner	1
BRSLODVR	or Riello Burner	1
DVKIT	Direct vent kit	1
OILVNTXX	Flue and combustion air venting	1

POSITIONING THE FURNACE

Installation Diagram

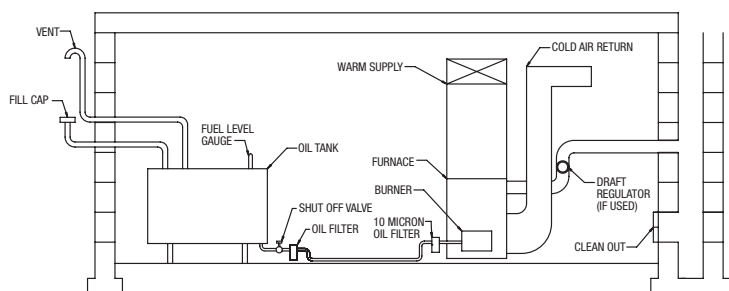

It is important to know the location and operation of the emergency power isolation switch. Ask your service technician.

It is always important to consider the effects that remodeling may have on your heating system. Contact a qualified service technician prior to remodeling.

Should it be necessary to decommission this appliance for an extended period, call your qualified technician to re-commission it.

! WARNING

Fire and explosion hazard.
The furnace must be installed in level position, NEVER where it will slop toward the front. Do not store or use gasoline or any other flammable substances near the furnace.
Non-observance of these instructions will potentially result in death, bodily injury and/or property damage.

CAUTION

This furnace is not watertight and is not designed for outdoor installation. It must be installed in such a manner as to protect its electrical components from water. Outdoor installation will lead to hazardous electrical condition and to premature failure of the equipment.

The minimum clearances from combustibile material for each of the positions are specified on page 14.

If the furnace is installed in a basement or on a dirt floor, in a crawl space for example, it is recommended to install the unit on a cement base 2.5cm to 5.0 cm (1" to 2") thick.

The unit must be installed in an area where the ambient and return air temperatures are above 15°C (60°F). In addition, the furnace shall be installed as closely as possible to the chimney vent, so that the connections are direct and kept to a minimum. In Direct Vent installations, it is recommended that the combustion air duct be long enough to temper the combustion air. The furnace should also be located close to the center of the air distribution system.

INSTALLATION IN AN ENCLOSURE

The unit can be installed in an enclosure such as a closet. However, two (2) ventilation openings are required for combustion air. Each opening shall have a free flow area of 22cm² (sq. inch) per 1000 BTU of total input rating of all appliances in the enclosed area. The openings should be located in front of the furnace approximately 15 cm (6") above the floor and 15 cm (6") below the ceiling.

Ventilation Diagram

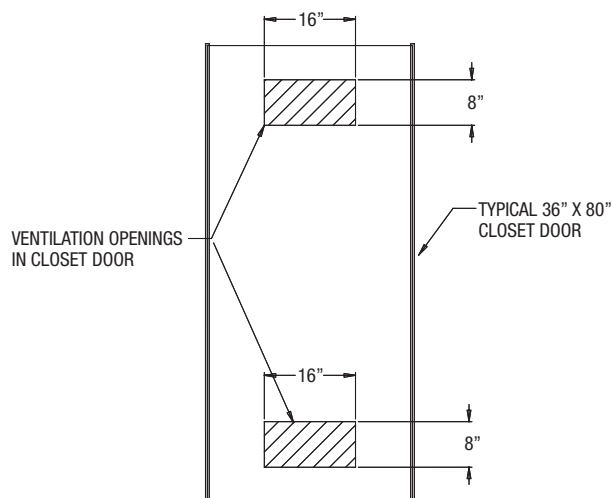

ELECTRICAL SYSTEM

The appliance must be installed in accordance with the current version of the ANSI/NFPA 70 National Electric Code, CSA C22.1 Canadian Electric code part 1 and/or local codes.

The control system depends on the correct polarity of the power supply. Connect "HOT" wire (H) and "NEUTRAL" wire "N" as indicated on the power supply terminal block in the unit.

A separate line voltage supply should be used, with fused disconnect switch or circuit breaker, between the main power panel and the unit.

Only copper wire shall be used for the 115V circuit on this unit. If wires need to be changed, the replacements must have the same temperature resistance as the originals.

INSTALLATION OF THE THERMOSTAT

A thermostat must be installed to control the temperature of the area to be heated. Follow the instructions supplied with the thermostat. Also refer to the wiring diagrams provided with the heating/ air conditioning unit. The connections must be made as indicated on the wiring diagram.

STAGED COOLING (ECM Design ONLY)

Note: On units with 2 stage compressors, terminal Y1 on the electronic control receives a 24 VAC signal, the air flow is reduced by 55%. **Do not** use terminal Y1 with a single stage compressor.

INSTALLATION OF THE OIL BURNER

Refer to the burner Manufacturer's instructions

1. Burner must ALWAYS be positioned "right way" up.
2. Position the mounting gasket between the mounting flange and the burner mounting plate. Align the holes in the burner mounting plate with the studs on the mounting flange and bolt securely in place.
3. Check the electrode settings.
4. Make the electrical connections.
5. Complete oil line connections.

NOZZLES

The burner comes equipped with the factory installed nozzle. However if another size or replacement nozzle is required, refer to Table 1 Alternate nozzles are provided with the burner. Always select nozzle sizes by working back from the desired flow rate at operating pressure and not the nozzle marking.

AIR AND TURBULATOR SETTINGS

The air and turbulator settings are factory set, the factory installed nozzle is .60 usgph x 70 deg. w delavan. Before starting the burner for the first time, adjust the air and turbulator settings to those listed in Table 1.

Once the burner becomes operational, final adjustments will be required.

VENTING

! WARNING

Poisonous carbon monoxide gas, fire and explosion hazard.

Read and follow all instructions in this section. Failure to properly vent this furnace can result in death, bodily injury and/or property damage.

To ensure the safe and proper functioning of an oil furnace, it must always be connected to a flue with sufficient draft or to a certified Summerraire sidewall venting system. In addition, a complete inspection of any existing venting system is required.

! WARNING

Poisonous carbon monoxide gas, fire and explosion hazard.

Never install a hand-operated damper in the vent pipe. However, any Underwriters laboratories listed electrically operated automatic type vent damper may be installed if desired. Be sure to follow the instructions in the section of the manual. Failure to properly vent this furnace or other appliances can result in death, bodily injury and/or property damage.

BFS Blocked Flue Switch (Chimney vent only)

The blocked flue switch must be installed in the breech pipe in the opening provided. Remove the cover plate (2 screws). Re-Install screws and install blocked flue switch. Ensure gasket is in place to provide air tight seal. Unplug connector at rear of furnace and plug into receptacle in electrical control box at front of furnace. Plug blocked flue switch into connector in rear of furnace.

This device is designed to detect the insufficient evacuation of combustion gasses in the event of a vent blockage. In such a case the thermal switch will shut down the oil burner.

In the event the BFS is tripped, it will need to be re-set manually.

To reset it the switch cover must be removed and the red reset button pushed. The Blocked Flue Switch (BFS) mounting location is factory installed on the furnace breech pipe. To install the switch remove the opening cover plate and secure BFS into place and plug it in to the

socket at the rear.

It is essential that the BFS be **maintained annually**. For more details refer to the instructions supplied with the device itself.

Part number 2.BFSSHO (blocked flue switch) must be ordered separately and MUST be installed in the position provided on the furnace breech when this appliance is chimney vented.

Notice: Consideration Must be given to Chimney type and selection. Refer to CSA Standard B139 “Permitted chimney vent (flue) sizes and minimum base temperatures”

MASONRY CHIMNEY

Refer to B139 and/or local codes and standards for specific requirements.

This furnace can be vented into an existing lined masonry chimney. However, the unit must not be vented into a chimney which a solid fuel burning furnace is already vented.

Before venting this furnace into a chimney, its condition must be inspected and repairs made, if necessary. Also, the chimney lining and dimensions must conform to local and National codes, and to the Minimum Base Temperature Requirement of the most recent edition of CSA B139

FACTORY BUILT CHIMNEYS

Oil fired furnaces are approved for use with “L” type vents. The unit may also be used with an approved chimney of proper dimensions and temperature ratings as specified in the installation code. Refer to chimney manufacturer’s instructions for proper installation.

DRAFT REGULATOR

This unit may be installed with or without a draft regulator. However, it is recommended that a draft regulator be installed in cases where the draft is either high or variable due to external conditions. The draft regulator must be mounted with the hinge pins in a horizontal position and the face of the damper vertical for proper functioning. Furnace shall be firing for at least 5 minutes before making any adjustments. Draft should be set to between -.02 to -.08. Follow the instructions provided with the regulator. It is necessary that the chimney base temperature be verified and confirmed to meet minimum standard requirements. Too low of a base temperature may result in condensing of the flue gases potentially harming the chimney. Oil fired furnaces shall be connected to a vent having sufficient draft at all times to ensure safe and proper operation of the appliance.

SIDE-WALL VENTING

The heating unit is approved for side-wall venting. This vent system is comprised of a model 2.DVKIT as well as a venting kit, model 2.OILVNTXX side wall vent kit, 3” combustion air pipe and a 3” insulated vent pipe up to 20 ft. in length. Vent kits are available in lengths of 5 ft to 20 ft, in increments of 5 ft. Identified as 2.OILVNT5,10,15,20.

When installing a Direct Vent System, consideration must be given to the following.

- Combustion efficiency tests should be done at the port provided in the breech vent connector, do not puncture the stainless steel vent tubing.
- Only use Summerraire supplied Direct Vent Systems. Be selective in the location of the vent terminal, minimum clearances are required. As indicated in the instructions provided with the vent kit.
- If possible the vent terminal should not be located on a wall that is exposed to prevailing winds. If possible, locate it on the south or east wall of the building.
- Position the vent terminal at least 12” above the anticipated snow level and at least 3 ft from any inside corner.
- The vent terminal shall not be less than 1 (m) 3 ft above any forced air inlet into the building that is located within 1.8 (m) 6 ft of the terminal.
- The vent terminal shall not be less than 1.8 (m) 6 ft below, 1.8 (m) 6 ft horizontally, or 1.8 (m) 6 ft above any door, openable window, or gravity inlet into any building.
- The vent terminal shall not be installed in a window well.
- The vent terminal shall not be less than 1.8 (m) 6 ft from the property line.
- The vent terminal shall not be less than 2.13 (m) 7 ft above grade when located adjacent to public walkways.
- The vent terminal shall be so located that flue gases are not directed to jeopardize people, overheat combustible structures or materials or enter buildings.
- All joints in the vent system are to be sealed with high temperature sealant to prevent leakage. This applies to all joints and seams.
- The vent terminal should not be installed above or within 1 (m) 3 ft horizontally from a gas meter, electric meter or air conditioning condenser.
- Refer to the installation instruction provided with the venting system.
- Exhaust flue vent shall be supported every 3 ft and maintain a 1/8” to ¼” rise per foot from the furnace breech to the vent terminal.
- Installation must also comply with the requirements of all local and provincial building codes.
- The combustion air inlet of the Vent Terminal MUST be positioned to the bottom.

CAUTION

A positive pressure venting system (Sealed Combustion System or Direct Vent) **MUST NOT** use the BFS (Blocked Flue Switch). Follow the instructions supplied with the venting system.

COMBUSTION AIR SUPPLY AND VENTILATION

! WARNING

Poisonous carbon monoxide gas hazard.
Comply with NFPA 31 (U.S.) and CSA B139 (Canada) standards for the installation of Oil Burning Equipment and applicable provisions of local building codes to provide combustion and ventilation air.
Failure to provide adequate combustion and ventilation air can result in death, bodily injury and/or property damage.

Oil furnaces must have an adequate supply of combustion air. It is common practice to assume that older homes have sufficient infiltration to accommodate the combustion air requirement for the furnace. However, home improvements such as new windows, doors and weather stripping have drastically reduced the volume of air infiltration into the home.

Refer to oil furnace installation codes relative to combustion and ventilation air requirements.

Home air exhausters are common. Bathroom and kitchen fans, power vented clothes dryer and water heaters all tend to create a negative pressure condition in the home. Should this occur the chimney becomes less and less effective and can easily downdraft. In certain cases, mechanically supplied air, by way of a blower, interlocked with the unit, is necessary. It is the installer's responsibility to check that.

CONTAMINATED COMBUSTION AIR

Installations in certain areas or types of structures will increase the exposure to chemicals or halogens that may harm the furnace. These conditions will require that only outside air be used for combustion.

The following areas or types of structures may contain or be exposed to certain substances, potentially requiring outside air for combustion:

- a. Commercial buildings
- b. Buildings with indoor pools
- c. Furnaces installed near chemical storage areas

Exposure to the following substances:

- a. Permanent wave chemicals for hair
- b. Chlorinated waxes and cleaners
- c. Chlorine based swimming pool chemicals
- d. Water softening chemicals
- e. De-icing salts or chemicals
- f. Carbon tetrachloride
- g. Halogen type refrigerants
- h. Cleaning solvents (such as perchloroethylene)
- i. Printing inks, paint removers, varnishes etc. Hydrochloric acid
- j. Solvent based glue
- k. Antistatic fabric softeners for clothes dryers
- l. Acid based masonry cleaning materials

BURNER WITH OUT DOOR COMBUSTION AIR KIT

The burner provided is designed to function with combustion air taken directly from the outside. Follow the instructions provided with the burner, the fresh-air supply kit or the side-wall venting kit

DIRECT VENT PRESSURE SWITCH ASSEMBLY (DVPS) SHUT-OFF DEVICE FOR DIRECT THROUGH THE WALL VENTING

This device is designed to detect the insufficient evacuation of combustion gasses or inadequate supply of combustion air. In the event of a vent blockage the associated pressure switch will shut down the oil burner. Only after the obstruction in the vent has been removed will the burner function normally.

This pressure switch assembly is provided with the Direct Vent Kit and must be field installed onto the furnace. Refer to the provided instructions with the Vent Kit.

DEBOUNCE RELAY

In all direct vent applications the debounce relay must be installed and wired into the control circuit. This relay is factory installed.

OIL TANK

! WARNING

Fire and explosion hazard.
Use only approved heating type oil in this furnace.
DO NOT USE, waste oil, used motor oil, gasoline or kerosene.
Use of these will result in death, bodily injury and/or property damage.

CAUTION

When using .40 USGPH nozzles, 2-stage oil filtration is required. Stage 1 located at the oil tank and stage 2, a 10 micron or finer filter located as close as possible to the furnace.
This is a requirement in order for the heat exchanger warranty to remain in force.

Check your local codes for the installation of the oil tank and accessories. At the beginning of each heating season or once a year, check the complete oil distribution system for leaks. Ensure that the tank is full of clean oil. Use No. 1 or No. 2 Heating Oil (ASTM D396 U.S.) or in Canada, use No. 1 or No. 2 furnace oil.

A manual shut-off valve and oil filter shall be installed in sequence from tank to burner. Be sure that the oil line is clean before connecting to the burner. The oil line should be protected to eliminate any possible damage. Installations where the oil tank is below the burner level must employ a two-pipe fuel supply

system with an appropriate fuel pump. A rise of 2.4m (8') and more requires a two stage pump and a rise greater than 4.9 m (16') an auxiliary pump. Follow the pump instructions to determine the size of pipe needed in relation to the rise or to the horizontal distance.

DUCTING

! WARNING

Poisonous carbon monoxide gas hazard.
DO NOT draw return air from a closet space or utility room. Return air ductwork MUST be sealed to the furnace casing.
Failure to properly seal ducts can result in death, bodily injury and/or property damage.

The ducting must be designed and installed according to approved methods, local and national codes as well as good trade practices.

When ducting supplies air to a space other than where the furnace is located, the return air must be sealed and also be directed to the space other than where the furnace is located.

AIR FILTER

Properly sized certified air filter's must be installed on the return airside of the unit. The air filter's shall be replaced ONLY with the exact type and size as supplied with the furnace.

SUPPLY AIR ADJUSTMENTS (3 SPEED MOTORS)

Only on units equipped with 3-speed blower motors, the supply air must be adjusted based on heating/ air conditioning output and the static pressure of the duct system. For the desired air flow refer to the following table as well as the air flow tables based on static pressure in the Technical Specifications section of this manual.

Blower Speed Adjustments(3 Speed Motor)		
Furnace Application	Heating or A/C Output	Recommended Blower Speed
Heating	0.5 USGPH	Med.-High
	0.60 USGPH	Med.-High
	0.70 USGPH	High
A/C	2.0 TONS	Med.-High
	2.5 TONS	Med.-High
	3.0 TONS	High

To effect the adjustment the motor speed tap wires can be relocated on the control. Also, refer to the position of the wires on the electronic board of the unit and consult the wiring diagrams. If the heating and air conditioning speeds are the same, the unused wire must be moved to "PARKED POSITION" on the electronic board a jumper provided between the "HEAT" and "COOL" terminals.

The blower start/ stop delays can be adjusted by positioning

the dipswitches on the electronic board as shown in the wiring diagram

SUPPLY AIR ADJUSTMENTS, MODEL SHO80E (ECM VARIABLE SPEED MOTORS)

On units equipped with ECM variable speed blower motors, the air supply must be adjusted based on heating/ air conditioning output. Refer to the following tables and the wiring diagram in this manual for the proper settings. Final determination of fan speed selections shall be confirmed by measuring temperature rise through the furnace. Not to exceed 85 F based on a return air temperature of 75 F.

NOTE: FURNACE MUST BE POWERED DOWN PRIOR TO MAKING ANY DIPSWITCH CHANGES

Dip Switch references in the following table are located on the Tap Select Board.

- Switches 1 and 2 - Heat Mode Fan speed
- Switches 3 and 4 – CFM Adjust
- Switches 5 and 6 – Cooling Mode fan speed
- Switches 7 and 8 – Heating Mode fan operating profiles.

HEATING MODE @ .20" W.C. ESP

DIP Switch positions			Output USGPH
1	2	CFM	
OFF	OFF	1150	0.70
OFF	ON	950	0.60
ON	OFF	750	0.50

AIR CONDITIONING MODE @ .50" W.C. ESP

DIP Switch positions			Output Tons
5	6	CFM	
OFF	OFF	1150	3.0
OFF	ON	900	2.5
ON	OFF	700	2.0
ON	ON	530	1.5

CFM ADJUSTMENTS- ALL MODES

DIP Switch positions		CFM HTG.	CFM A/C
3	4	% Increase or Decrease	% Increase or Decrease
ON	OFF	+10%	+10%
OFF	OFF	0%	0%
OFF	ON	-10%	-10%

DELAY ADJUSTMENTS – HEATING MODE

DELAY Profiles					Output USGPH
DIP Switch positions CFM % & Time (Seconds)					
7	8	PreRun On Delay	Short Run On Delay	Fan Off Delay	
ON	ON	25% -30	70%-120	70%-240	0.70
ON	OFF	25%-45	50%-150	70%-180	0.60
OFF	ON	25%-45	50%-150	65%-180	0.50
OFF	OFF	25%-45	50%-180	65%-120	ALL

INSTALLATION OF ACCESSORIES

! WARNING

Electrical shock hazard.

Turn off electrical power at fuse box or service panel before making any electrical connections and ensure a proper ground connection is made before connecting line voltage.

Failure to do so can result in death or bodily injury.

HUMIDIFIER (HUM)

The 120VAC HUM output on the electronic board (PSC motor design only) is powered when the burner is in operation.

ELECTRONIC AIR CLEANER (PSC motor design only)

The EAC terminal on the electronic board supplies 120 VAC when the blower is operating in the heating or air conditioning mode. This signal can be used to activate an electronic air cleaner that is not equipped with an airflow switch. If the air cleaner is equipped with an airflow switch, the EAC terminal on the electronic board can be used to provide a constant supply of 120 VAC.

Also refer to the instructions supplied with the accessory.

AIR CONDITIONER (OR HEAT PUMP)

An air conditioner coil may be installed ONLY on the supply, downstream airside.

! WARNING

Poisonous carbon monoxide gas hazard.

Install the evaporator coil on the supply side of the furnace ducting only.

An evaporator coil installed on the return airside of the ducting can cause condensation to form inside the heat exchanger, resulting in heat exchanger failure. This in turn can result in death, bodily injury and/or property damage.

A clearance of 15cm (6") is required between the bottom of the coil drain pan and the top of the heat exchanger. If the heat

pump is installed, a “dual energy” thermostat, or other control is required, in order to prevent the simultaneous operation of the furnace and the heat pump. It also prevents a direct transition from heating by way of the heat pump to heating with oil. Refer to the thermostat instructions or those of another control used for the proper wiring.

OPERATION

START-UP

Before starting up the unit, be sure to check that the following items are in compliance:

1. The electrical installation, the oil supply system, the venting system, combustion air supply and ventilation
2. The blower rail locking screws are well tightened and the blower access door is in place
3. The oil supply valve is open
4. The preliminary air adjustments on the burner comply with the technical specifications in this manual
5. The blower speed adjustments for heating and air conditioning are appropriate and according to the specifications in this manual
6. The blower start/stop delays are satisfactory
7. The thermostat of the room is in the heating mode and is set higher than the ambient temperature.

To start the unit, turn the main electrical switch on.

CAUTION

DO NOT USE GASOLINE, CRANKCASE OIL, OR ANY OIL CONTAINING GASOLINE; NEVER BURN GARBAGE OR PAPER IN THE HEATING SYSTEM, AND NEVER LEAVE PAPER OR RAGS AROUND THE APPLIANCE.

OPERATING SEQUENCE OIL HEATING MODE

1. The W-R contact closes
2. The burner motor starts up to pre-purge the combustion chamber for a period of 10 to 15 seconds. During that time a spark is established on the electrodes
3. The solenoid valve opens and a flame is established. Shortly after, the electrodes cease to spark.
4. The blower runs up to the selected speed. The delay depends on the adjustments that were made on the PSC motor design electronic board or the ECM Tap Select board, which controls the blower motor
5. When the call for heat is satisfied, the solenoid valve closes, the burner motor stops, and the flame goes out.
6. The furnace blower stops shortly after the burner. The delay depends on the adjustments that were made on the PSC motor design electronic board or the ECM Tap Select board, which controls the blower motor

Note: A detailed operating sequence of the oil burner is outlined in the instructions with the oil burner.

CHECKS AND ADJUSTMENTS

IMPORTANT

The burner must be in operation for 15 minutes before test readings are taken to adjust the furnace. Adjustments Are to be made according to the technical specifications contained in this manual.

PURGING THE OIL LINE

Open the bleed port screw and start the burner. Allow the oil to drain into a container for at least 10 seconds. The oil should flow absolutely free of white streaks or air bubbles to indicate that no air is being drawn into the suction side of the oil piping and pump. Slowly close and tighten the bleed screw. Once closed, the flame will light up.

PRESSURE ADJUSTMENT

The oil pressure must be adjusted according to the Technical Specifications of this manual. An adjustment screw and a connection for a pressure gauge are located on the oil pump for that purpose. Also, refer to the burner instruction manual.

DRAFT REGULATOR ADJUSTMENT

On chimney installations only, a barometric draft regulator (supplied with the furnace) may be installed, in order to ensure proper draft through the furnace. The barometric damper must be mounted with the hinge pins in a horizontal position and the face of the damper vertical for proper functioning (see instructions included with the damper.) After the furnace has been firing four at least five minutes, the draft regulator should be set to between $-.025''$ and $.035''$ W.C.

OVER FIRE PRESSURE TEST

The over fire draft that is taken through the observation port, located above the burner, is a measurement necessary to determine if there is a blockage in the heat exchanger or the flue pipe. Refer to the Technical Specifications in this manual for over fire pressure values. A high-pressure condition may be caused by excessive combustion air. This is due to the air band being to wide open, or a lack of flue draft (chimney effect) or some other blockage, such as soot in the secondary section of the heat exchanger or the use of an oversized nozzle input or high pressure pump.

Restart after burner failure

- 1) Set the thermostat lower than room temperature.
- 2) Press the reset on the burner primary control.
- 3) Set the thermostat higher than room temperature
- 4) If burner motor does not start or ignition fails turn off, disconnect switch and call a qualified service technician.

COMBUSTION CHECK

1. Pierce a test hole in the smoke pipe, near the furnace breech. Insert the smoke test probe into the hole. Do not pierce any holes in the direct venting pipe or breech

pipe connector. Remove test port cover provided on the breech connector .

2. Starting with a 0 smoke reading, gradually reduce the burner air setting until just a trace of smoke results (#1 on the Bacharach Scale)
3. Take the CO₂ at the same test location where the #1 smoke reading was taken and make note of it. Approximate CO₂ readings are as follows;

.40 usgph nozzle @ 150 psi – 11.13
.50 usgph nozzle @ 150 psi – 12.03
.60 usgph nozzle @ 150 psi – 13.25
.65 usgph nozzle @ 150 psi – 13.81
4. This method of adjusting the burner will result in clean combustion and ensure the proper functioning of the system.
5. Test hole must be sealed once burner set up is complete.

VENT TEMPERATURE TEST

1. After having adjusted the burner combustion, insert a thermometer into a test hole in the breech pipe or breech pipe connector.
2. The vent temperature should be between 150 and 230°C (300 and 450°F). If not, check for improper air temperature rise, pump pressure, nozzle size or a badly sooted heat exchanger.
3. Minimum chimney base temperature must be verified to ensure that flue gases do not condense causing chimney failure. Refer to most recent edition of CSA B139

SUPPLY AIR TEMPERATURE RISE TEST

1. Operate the burner for at least 10 minutes
2. Measure the air temperature in the return air plenum
3. Measuring the air temperature in the largest trunk coming off the supply air plenum, just outside the range of radiant heat from the heat exchanger. 0.3m (12") from the plenum of the main take-off is usually sufficient.
4. The temperature rise is calculated by subtracting the return air temperature from the supply air temperature.
5. If the temperature rise exceeds the temperature specified in table 1, change to the next higher blower speed tap, until the temperature rise falls to the target or below. If increasing the fan speed can not reduce the excessive temperature rise, investigate for ductwork under sizing, obstructions dirty or improper air filter, overfiring caused by excessive pump pressure or improper nozzle sizing.

LIMIT CONTROL CHECK

After operating the furnace for at least 15 minutes, restrict the return air supply by blocking the filters or the return air duct and allow the furnace to shut off on high limit. The burner will shut off but the blower will continue to run.

Remove the obstruction and the burner should restart after a few

minutes. The time required for the restart also depends on the adjustment of the blower "off" delay.

RESTART AFTER BURNER FAILURE

1. Set the thermostat lower than room temperature
2. Press the reset button ONCE ONLY on the burner primary control (relay)
3. Set the thermostat higher than room temperature
4. If the burner motor does not start or ignition fails, turn off the disconnect switch and call a QUALIFIED SERVICE TECHNICIAN

CAUTION

Do not attempt to start the burner when excess oil has accumulated, when the furnace is full of vapor or when the combustion chamber is hot.

MAINTENANCE

! WARNING

Electrical shock hazard.
Turn OFF power and fuel to the furnace before ANY disassembly or servicing.
Failure to do so can result in death or bodily injury.

Preventative maintenance is the best way to avoid unnecessary expense and inconvenience. Have your heating system and burner inspected by a qualified service technician at regular intervals.

To maintain the reliability and optimal performance of the furnace, have a complete combustion check done after the annual maintenance call. Do not attempt to repair the furnace or its controls. Call a qualified service technician.

Before calling for service check the following points:

1. Check the oil tank gauge and make sure that the valve is open.
2. Check the fuses and circuit breaker.
3. Check if the main disconnect switch is ON
4. Set the thermostat above room temperature
5. If ignition does not occur, turn off the disconnect switch and call a qualified service technician.

When ordering replacement parts, please specify the complete furnace model number and serial number.

REGULAR MAINTENANCE (In Canada refer to B139 Sec. 14)

Preventative maintenance is the best way to avoid unnecessary expense and inconvenience. Have your heating system and burner inspected by a qualified service technician at regular intervals. Have a complete inspection check done after the maintenance call. Do not attempt to repair the furnace or its controls. Call a qualified service technician.

CLEANING THE HEAT EXCHANGER

It is not generally necessary to clean the heat exchanger or flue pipe every year, but it is advisable to have the oil burner service technician check the unit before each heating season to determine whether the cleaning or replacement of parts is necessary.

If a cleaning is necessary, the following steps should be performed:

1. Turn off all utilities upstream from the furnace
2. Access the secondary portion of the heat exchanger by removing the 8 brass nuts and the cover plate, DO NOT remove the breech vent connector from the vent pipe or furnace breech access cover plate. This is a permanent sealed joint
3. Disconnect the oil line and remove the oil burner
4. Clean the secondary tubes and primary cylinder with a stiff brush and a vacuum cleaner
5. Before re-assembling the unit, the heat exchanger should be inspected to determine if replacement is required
6. After cleaning replace the flue collar plate gasket, flue collar plate and oil burner.
7. Readjust the burner for proper operation

CLEANING THE BLOCKED FLUE SWITCH (BFS) SHUT-OFF DEVICE CHIMNEY VENT

For continuous safe operation, the BFS must be inspected and maintained annually by a qualified service technician.

1. Disconnect power to the appliance
2. Remove the screws holding on the BFS assembly cover
3. Remove the cover
4. Carefully remove any build-up from the thermal switch surface
5. Remove the screws holding the thermal switch to the BFS casing.

CAUTION

Do not dent or scratch the surface of the thermal switch. If the thermal switch is damaged it MUST be replaced.

6. Clean and remove any build-up or obstruction inside the heat transfer tube.
7. Re-mount the thermal switch.
8. Re-attach the assemblies cover with the screws removed in step 2.
9. Re-establish power to the unit.

We recommend that ALL service and cleaning required on your Summaire furnace be carried out by a Qualified Technician, or, where required by the local authority, a licensed Technician.

CLEANING OF THE BURNER HEAD

Once annually, remove the retention head and electrodes from the drawer assembly and remove all foreign matter, if necessary. Also clean the extremity of the burner tube, if necessary.

FUEL TANK AND LINES

Inspect the fuel oil tank and lines for leaks and replace if necessary.

REPLACING THE NOZZLE

Replace the nozzle once a year with one specified in table 1.

REPLACING THE OIL FILTERS

Tank Filter

The tank filter should be replaced as required follow the manufacturer's instructions.

Secondary Filter

The 10-micron or finer filter cartridge should be replaced annually. Follow the manufacturer's instructions

REPLACING THE AIR FILTER

Dirty filters have an impact on the efficiency of the furnace and increase fuel consumption.

Air filter should be replaced at least once every three months. Very dusty conditions, the presence of animal hair and such will require more frequent changing or cleaning.

The use of pleated filters is not recommended due to the high flow restrictions.

Replacement air filters must be exactly as the original supplied with your Summeraire furnace and must be CSA/UL Certified.

CLEANING AND REPLACING OF VENT CONNECTORS (FLUE PIPES)

Inspect and clean as required flue vent connectors, pipes and chimney.

In direct vent applications inspect and repair all seams and joints of the flue and combustion air vents to ensure they are air tight and leak free.

Replace defective venting components with approved Summeraire components only.

FUEL PUMP PRESSURE

Check the fuel pump pressure to make sure that the pressure conforms to furnace input selected in Table 1.

HIGH LIMIT CONTROL

Check the operation of the high limit control and replace if necessary.

Replace with correct approved Summeraire components only.

Failure to do so will result in improper operation of this appliance, resulting in possible injury, property damage or death.

COMBUSTION CHECK

Perform a combustion check to ensure CO, smoke, CO2 efficiency meets requirements.

DIRECT VENT PRESSURE SWITCHES

Inspect and test both the flue and combustion air pressure switch for proper operation. Replace if necessary. Flue pressure switch is preset to flip at 0.13" w.c.. Combustion air switch is preset to flip at 0.22" w.c.. These pressure switches are sealed and not adjustable. Only replace a defective switch with the correct line switch. Failure to do so will result in improper operation of the furnace. **SAFETY**

Table 1
Technical specifications

	WITH 1/3 HP PSC MOTOR					WITH 1/3HP ECM MOTOR				
RATING AND PERFORMANCE										
Firing rate (USGPH)	0.5	0.6	.7	.75	.83	0.5	0.6	0.7	.75	.83
Input (BTUH)	65,800	80,500	95,300	104,000	116,000	65,800	80,500	95,300	104,000	116,000
Heating temperature rise (°F)	35-85 (°F)					35-85 (°F)				
Flue draft with chimney (inch of w.c.)	-0.01 to -0.03					-0.01 to -0.03				
Overfire pressure with chimney (inch of w.c.)	-0.01 to +0.02					-0.01 to +0.02				
Flue draft with Direct Vent (inch of w.c.)	+.05 to +.15					+.01 to +.08				
Overfire pressure with Direct Vent (inch of w.c.)	+0.02 to +.13					+0.02 to +.13				
BECKETT BURNER NX(Chimney or DV)	NX WITH TUBE INSERTION 4"					NX WITH TUBE INSERTION 4"				
Head type	6-Slot					6-Slot				
Nozzle (Delevan)	0.50 - 60W	0.50 - 60W	0.60-70W	0.65-70W	0.75-70W	0.50 - 60W	0.50 - 60W	0.60-70W	0.65-70W	0.75-70W
Pump pressure (PSIG)	100	170	160	150	140	100	170	160	150	140
Head/ Air setting	1.0	1.2	1.6	1.8	2.0	1.0	1.2	1.6	1.8	2.0
Input (BTU/H)	65,800	80,500	95,300	104,000	116,000	65,800	65,000	95,300	104,000	116,000
Heating Capacity (BTU/H)	53,300	70,000	81,300	89,800	97,600	53,300	70,000	81,300	89,800	97,600
AFUE %	87.2	86.7	87.0	86.9	86.4	87.2	86.7	87.0	86.9	86.4
RIELLO BURNER 40-F3 (chimney)	F3 WITH TUBE INSERTION 4"					F3 WITH TUBE INSERTION 4"				
Nozzle (Delevan)	0.50 - 60W	0.50 - 60W	0.60-70W	0.65-70W	0.75-70W	0.50 - 60W	0.50 - 60W	0.60-70W	0.65-70W	0.75-70W
Pump pressure (PSIG)	100	170	160	150	140	100	170	160	150	140
Combustion air adjustment (turbulator damper)	2.1/0	2.3/0	2.7/0	3.0/0	4.0/0	2.1/0	2.3/0	2.7/0	3.0/0	4.0/0
Input (BTU/H)	65,800	80,500	95,300	104,000	116,000	65,800	80,500	95,300	104,000	116,000
Heating Capacity (BTU/H)	53,300	70,000	81,300	89,800	97,600	53,300	70,000	81,300	89,800	97,600
AFUE % (with air inlet damper)	87.2	86.7	87.0	86.9	86.4	87.2	86.7	87.0	86.9	86.4
RIELLO BURNER 40-BF3 (Direct vent DV)	BF3 WITH TUBE INSERTION 4"					BF3 WITH TUBE INSERTION 4"				
Nozzle (Delevan)	0.50 - 60W	0.50 - 60W	0.60-70W	0.65-70W	0.75-70W	0.50 - 60W	0.50 - 60W	0.60-70W	0.65-70W	0.75-70W
Pump pressure (PSIG)	100	170	160	150	140	100	170	160	150	140
Combustion air adjustment (turbulator damper)	2.1/0	2.3/0	2.7/0	3.0/0	4.0/0	2.1/0	2.3/0	2.7/0	3.0/0	4.0/0
Input (BTU/H)	65,800	80,500	95,300	104,000	116,000	65,800	80,500	95,300	104,000	116,000
Heating Capacity (BTU/H)	53,300	70,000	81,300	89,800	97,600	53,300	70,000	81,300	89,800	97,600
AFUE %	87.2	86.7	87.0	86.9	86.4	87.2	86.7	87.0	86.9	86.4
ELECTRICAL SYSTEM										
Volts-Hertz-Phase	115 / 60 / 1					115 / 60 / 1				
Rated current (Amps)	5.0					5.0				
minimum ampacity for wire sizing (Amps)	13.7					13.7				
Maximum fuse size (Amps)	15					15				
Control transformer (VA)	40					40				
External control power available Heating (VA)	40					40				
External control power available Cooling (VA)	30					30				
BLOWER DATA (side air return)										
Heating blower speed at 0.20" W.C. ESP	LOW	MED	MED	MED	MED	N/App	N/App	N/App	N/App	N/App
Air flow at 0.20" W.C. SP (CFM)	1030	1250	1250	1250	1250	850	1050	1250	1300	
Air flow at 0.50" W.C. SP (CFM)	875	1100	1100	1100	1100					
Motor (HP)/ Number of speeds	1/3 HP / 3 speeds					1/3 HP / ECM				
Blower wheel size (diameter x width)	10" x 10"					10" x 10"				
GENERAL INFORMATION										
Overall dimensions (width x depth x height)	18 1/4" X 42 3/4" X 31 1/4"					18 1/4" X 42 3/4" X 31 1/4"				
Supply air opening	16 3/4" W X 20"					16 3/4" W X 20"				
Return air opening	16 3/4" W X 16"					16 3/4" W X 16"				
Filter size	18" X 20"					18" X 20"				
Air conditioning, maximum output (tons)	3.0					3.5				
Shipping weight Lbs./kg (C/W burner)	175/80					175/80				

AIR FLOW CFM (1/3 HP, PSC motors)								
External Static Pressure (In. W.C.)	0.1	0.2	0.3	0.4	0.5	0.6	0.7	0.8
Motor Speed	1300	1300	1250	1200				
High	1150	1100	1080	1040	1000	890	800	670
Med	1080	1085	1052	1000	940	850	750	640
Low	960	978	925	895	830	750	640	500

MINIMUM CLEARANCES FROM COMBUSTIBLES		
SIDES	FURNACE (1)	0
	PLENUM AND WARM-AIR DUCT WITHIN 6 ft. OF FURNACE (1)	5.08 cm (2")
BOTTOM	FURNACE 2	0
BACK	FURNACE (OPPOSITE SIDE OF THE BURNER) (1)	30.48 cm (12")
TOP	PLENUM OR HORIZONTAL WARM-AIR DUCT WITHIN 6ft. OF FURNACE (2)	5.08 cm (2")
	FURNACE (2)	N/A
FLUE PIPE	AROUND FLUE PIPE	22.86 cm (9")
FRONT	FURNACE (BURNER SIDE) (1)	45.72 cm (18")

(1) These are horizontal dimensions

(2) These are vertical dimensions

(3) This dimension can be obtained by using downflow base # 2.SHOB

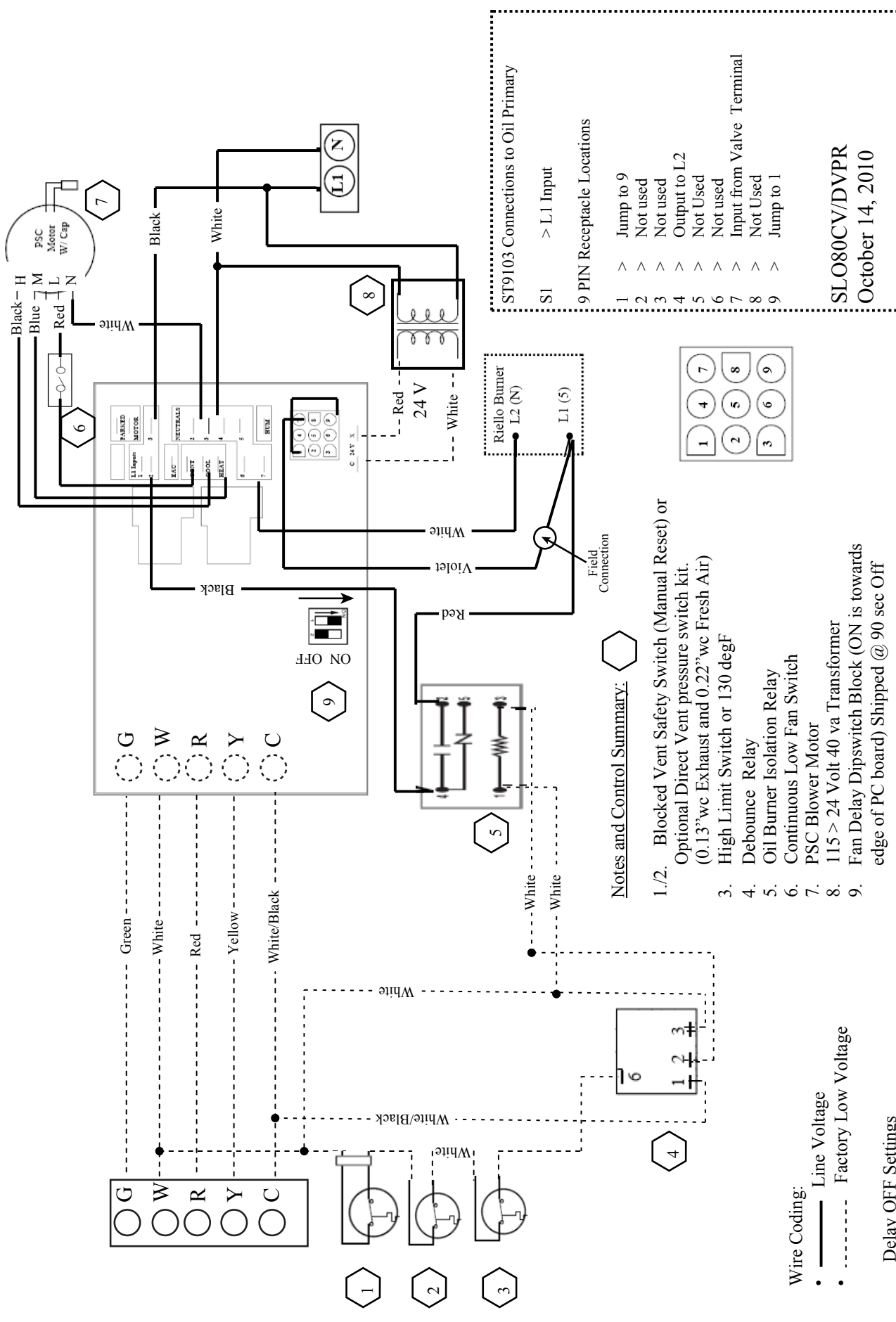

Notes and Control Summary:

- 1./2. Blocked Vent Safety Switch (Manual Reset) or Optional Direct Vent pressure switch kit. (0.13"wc Exhaust and 0.22"wc Fresh Air)
3. High Limit Switch or 130 degF
4. Debounce Relay
5. Oil Burner Isolation Relay
6. Continuous Low Fan Switch
7. PSC Blower Motor
8. 115 > 24 Volt 40 va Transformer
9. Fan Delay Dipswitch Block (ON is towards edge of PC board) Shipped @ 90 sec Off

Wire Coding:

- ——— Line Voltage
- - - - - - Factory Low Voltage

Delay OFF Settings

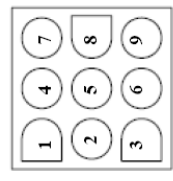
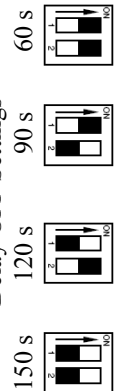

ST9103 Connections to Oil Primary	
S1	> L1 Input
9 PIN Receptacle Locations	
1	> Jump to 9
2	> Not used
3	> Not used
4	> Output to L2
5	> Not Used
6	> Not used
7	> Input from Valve Terminal
8	> Not Used
9	> Jump to 1

SLO80CV/DVPR
October 14, 2010

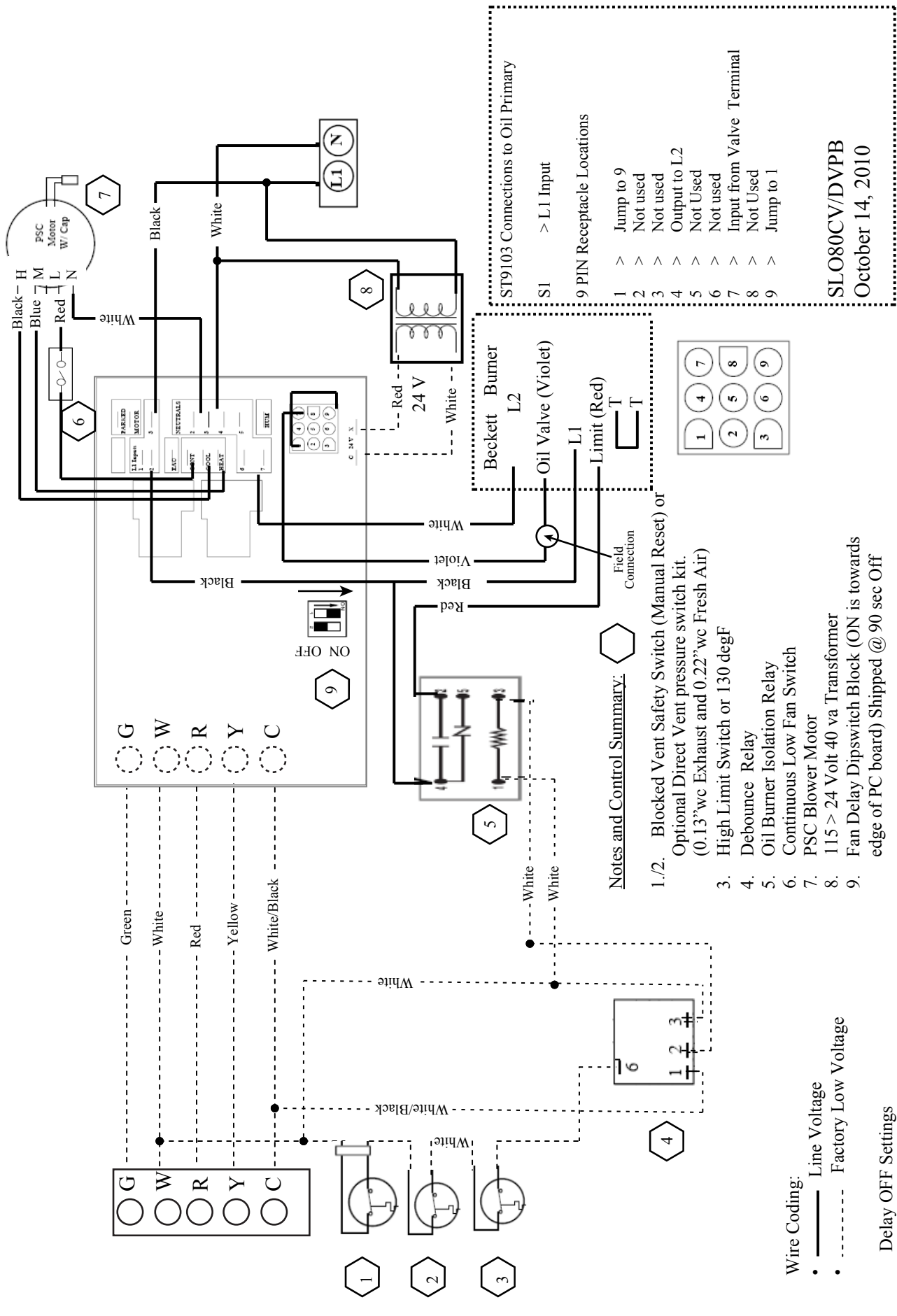

ST9103 Connections to Oil Primary

SI	>	L1 Input
----	---	----------

9 PIN Receptacle Locations

1	>	Jump to 9
2	>	Not used
3	>	Not used
4	>	Output to L2
5	>	Not Used
6	>	Not used
7	>	Input from Valve Terminal
8	>	Not Used
9	>	Jump to 1

SLO80CV/DVVPB
October 14, 2010

Notes and Control Summary:

- 1./2. Blocked Vent Safety Switch (Manual Reset) or Optional Direct Vent pressure switch kit. (0.13"wc Exhaust and 0.22"wc Fresh Air)
3. High Limit Switch or 130 degF
4. Debounce Relay
5. Oil Burner Isolation Relay
6. Continuous Low Fan Switch
7. PSC Blower Motor
8. 115 > 24 Volt 40 va Transformer
9. Fan Delay Dipswitch Block (ON is towards edge of PC board) Shipped @ 90 sec Off

Wire Coding:
 • — Line Voltage
 • - - - - - Factory Low Voltage

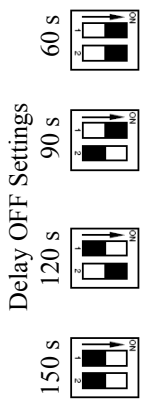

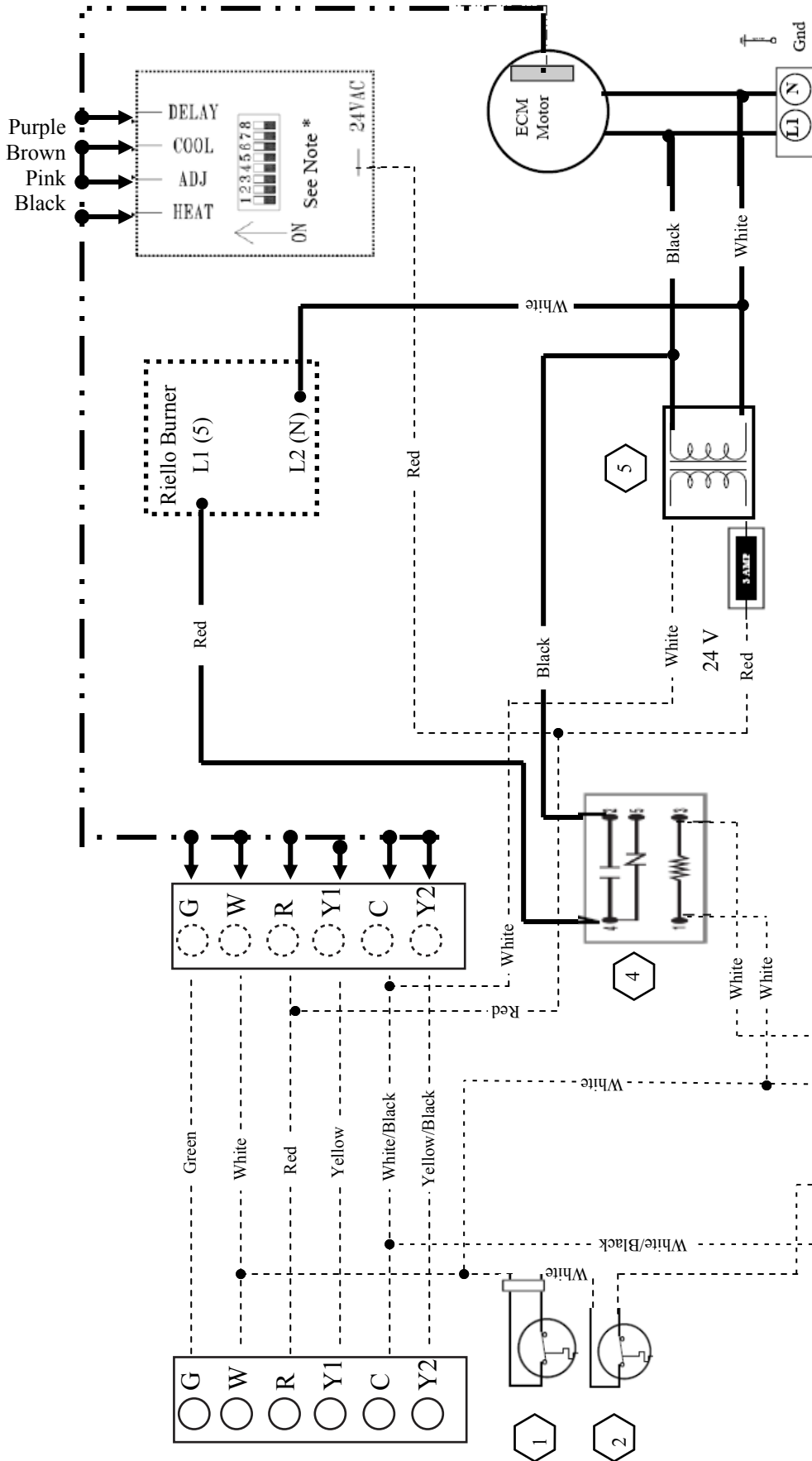

Wire Coding:

- — Line Voltage
- - - - - - Factory Low Voltage

Notes and Control Summary:

1. Blocked Vent Safety Switch (Manual Reset) or Optional Direct Flue Vent pressure switch kit. (0.13"wc flue vent and 0.22"wc Fresh Air)
2. High Limit Switch 130 degF
3. Debounce Relay
4. Oil Burner Isolation Relay
5. 115 > 24 Volt 40 va Transformer

Note: *

Tap Select Dipswitches are shown in the OFF position. Refer to page # 12 In your Install Manual for proper positioning.

SLO80CV/DVER
Nov. 4, 2010

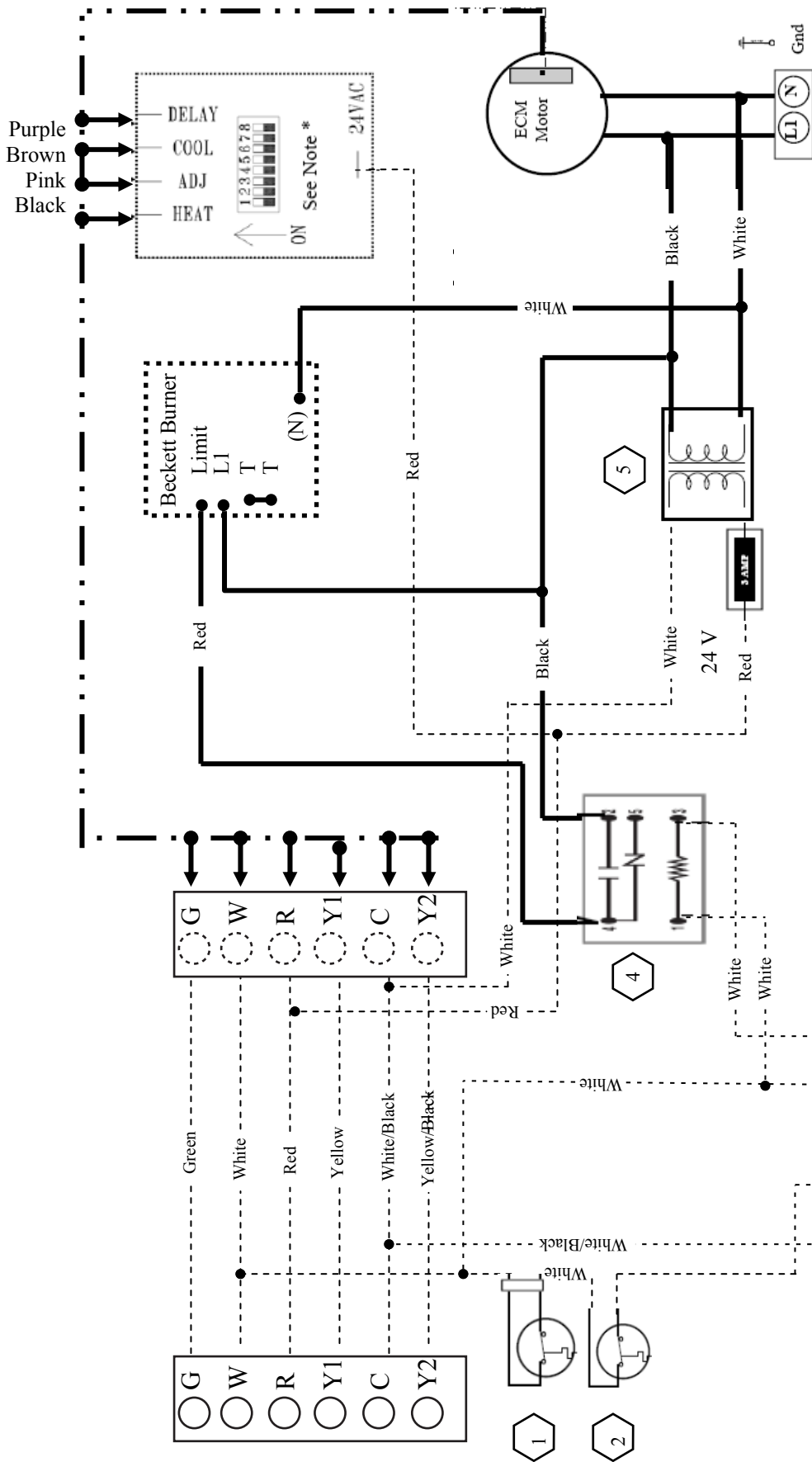

Note:* Tap Select Dipswitches are shown in the OFF position. Refer to page # 12 In your Install Manual for proper positioning.

Notes and Control Summary:

1. Blocked Vent Safety Switch (Manual Reset) or Optional Direct Flue Vent pressure switch kit. (0.13"wc flue vent and 0.22"wc Fresh Air)
2. High Limit Switch 130 degF
3. Debounce Relay
4. Oil Burner Isolation Relay
5. 115 > 24 Volt 40 va Transformer

Wire Coding:

- Line Voltage
- Factory Low Voltage

SLO80CV/DVEB
Nov. 4, 2010

SLO REPLACEMENT PARTS DIAGRAM

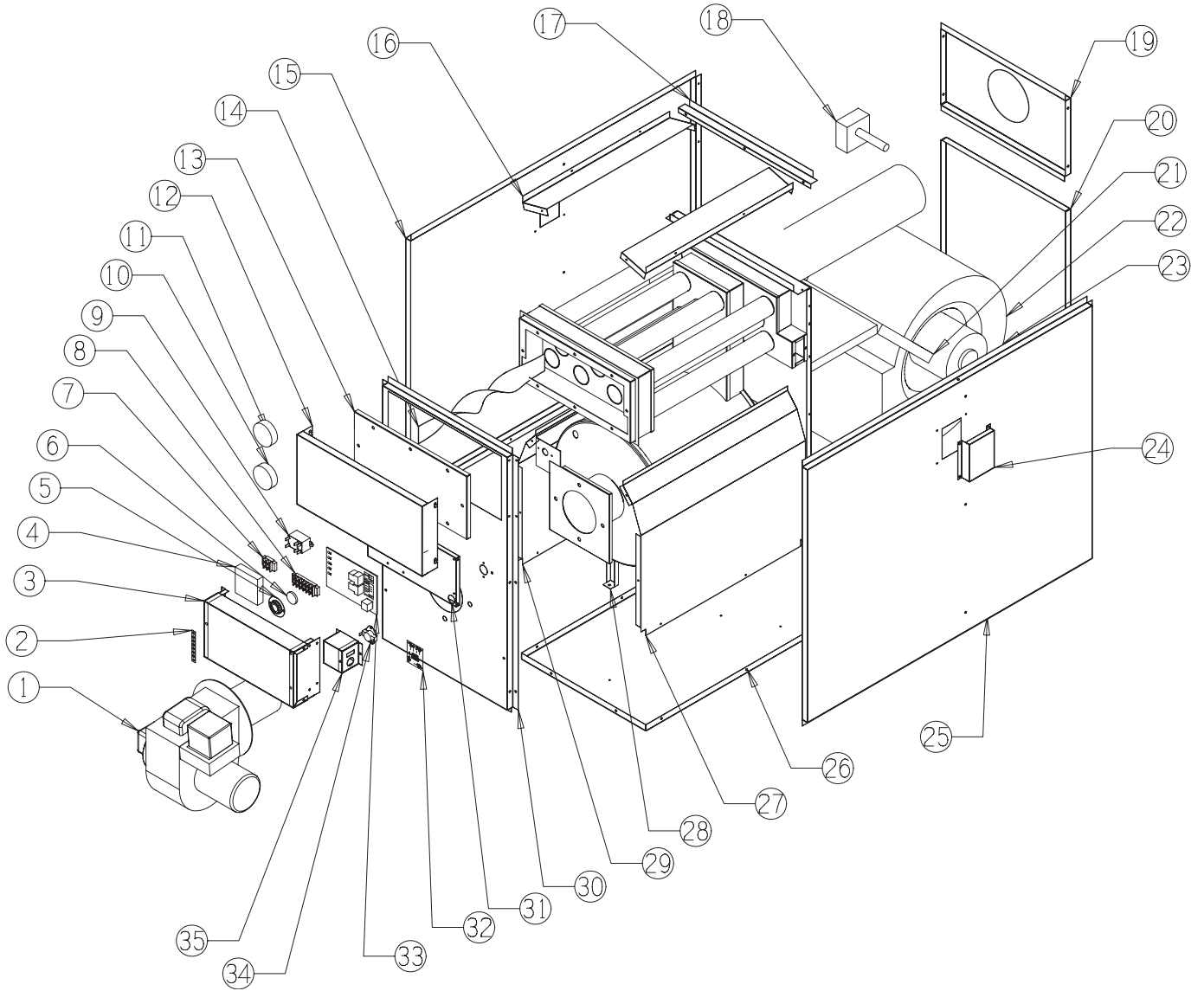

Replacement Parts

DIAGRAM #	PRODUCT	DESCRIPTION	FSSSHO80P	FSSSHO80E
1	2.BPSHOB	Beckett Burner NX2		
1	2.BPSHOCVR	Riello Burner Chimney Vented 40F3		
1	2.BPSHODVR	Riello Burner Direct Vented BF3		
1	2.BAFFLESLO80	Replacement baffle for SLO80 1 twist 1 5/8 x 17 1/2	6	6
2	2.TERMSTRIP6	6 point terminal strip 23-006	1	1
3	2.CNTRLCVR	Control Cover	1	1
4	2.RELAYQBS415	QBS415 Infitec Relay 5 second debounce delay off	1	1
5	2.SIGHTGLASSCVR	Sight Glass Cover	1	1
6	2.SIGHTGLASS	Replacement Sight Glass 3/16 x 1 1/4 dia.	1	1
7	2.TERMBLK3	3 Point terminal block TB200-03-SP		1
8	2.TERMBLK6	6 pole terminal block TB200-06-SP		1
9	2.RELAYSPDT	SPDT Relay 24V 90-370	1	1
10	2.SWITCHFA	Fresh Air Switch	1	1
11	2.SWITCHFA	Flue Switch	1	1
12	2.PNFALSE	False panel	1	1
13	2.CLEANOUTCVR	Clean out cover	1	1
14	2.BAFFLEFLUE	Secondary Tube Flue Baffle	6	6
15	2.PNLLSLO	Left Side Panel	1	1
16	2.AIRBAFFLE	Plenum Air Baffle	1	1
17	2.PNLPLENUM	Plenum Divider Panel	1	1
18	2.BFSSHO	Blocked Flue Switch	1	1
19	2.PNLURSLO	Panel Upper Rear	1	1
20	2.PNLFANDRSLO	Fan Door Panel	1	1
21	2.FILT18201	Replacement filter 18x20x1	1	1
22	2.BLWRGT10DD	Delhi blower GT10DD #9010663	1	1
23	2.MTR1864	Emerson motor #1864 1/3hp 3spd dd 115v 1075 rpm	1	
23	2.MTRSLO80ECM	ECM Motor 1/3 hp programmed for SLO80		1
24	2.PNLCLNOUT	Cleanout Cover Panel	1	1
25	2.PNLRSSLO	Right Side Panel	1	1
26	2.PNLBSLO	Bottom Panel	1	1
27	2.AIRBAFFLER	Right Side Air Baffle	1	1
28	2.HESLO80	Replacement Heat Exchanger SLO80	1	1
29	2.AIRBAFFLEL	Left Side Air Baffle	1	1
30	2.PNLF	Panel Front	1	1
31	2.CNTRPLATE	Control Mounting Plate	1	1
32	2.BOARDST9103A1002	Honeywell control board ST9103A1002	1	
33	2.BOARDTAP	Tap Select board for ECM units		1
34	2.LIMCONT130115	Limit control open@130, close@115	1	1
	2.SWITCHRCKR	Summ/ Switch WPGG-LRA911-RS (ON/OFF)	1	
	2.TRAN1202440	Transformer 120, 24V, 40VA class 2 inherent limiting	1	1
	8.CAP370V75MF	Capacitor 370V 7.5 MF	1	

WARRANTY:

Summeraire Mfg. warrants that it will supply to the owner of a Summeraire Oil furnace that has been installed in Canada, a replacement **Heat Exchanger** (Heat Element) free of charge F.O.B. Factory, Peterborough, Ontario, Canada. If the said **Heat Exchanger** wears out or fails under normal use and service due to a defect in material or workmanship during the first **Twenty (20) years** after the date of installation and only if the following conditions have been met.

1. The furnace has been installed and maintained in accordance with accepted practices as recommended from time to time by the Heating Refrigeration and Air Conditioning Institute of Canada; The National Building Code, or CSA standard B139 by a qualified installer.
2. The furnace has been operated with an input rate not in excess of the rating and fuel as specified on the rating plate attached to the furnace.
3. The furnace has not been operated with out the use of the proper automatic limit control on the maximum warm air temperature.
4. That the furnace has not been operated without adequate air circulation over it.
5. Proof satisfactory to Summeraire Mfg., that the defect claimed has not been caused by damage to, or destruction of the furnace.
6. The furnace has remained at all times in the place of initial installation.
7. Written notification of the failure under terms and conditions of this warranty are provided no later than thirty (30) days after the expiration of this warranty whichever shall first occur.
8. No mechanically cooled air. Originating in the return air duct shall be circulated over the heat exchanger of the furnace.
9. The owner must provide proof that the appliance has been serviced annually, including annual cleaning of the complete furnace and, inspection of the heat exchanger.
10. The unit must not be installed in any structure where a corrosive atmosphere exists as may be found in dry cleaning establishments, Laundromats, Beauty Salons, etc.
11. Summeraire Mfg. shall not be responsible for any failure due to water damage and/ or Acts of God.
12. No Air Conditioning or Heat pump coil may be installed on the return air side of this furnace.

This warranty expressly supersedes all other warranties and obligations of Summeraire Mfg. No person has authority to alter or modify the terms of this warranty in any manner. Summeraire Mfg. assumes no liability for consequential damages of any kind, and the purchaser, by acceptance of this Equipment assumes all liability for the consequence of its use or misuse, by the purchaser, his employee or others.

This **Warranty** is for the benefit of the owner of the furnace and terminates in the event of any alterations not specified by Summeraire Mfg. and other than herein provided. No further or other warranty, express or implied, is granted by this warranty and no liability shall accrue for any consequential damage resulting from alleged defects in the **Heat Exchanger** or its component parts.

Mechanical components for this furnace are covered under a five (5) year warranty.

If these components fail under normal use and service within five (5) years from date of installation, the defective part will be replaced free of charge, F.O.B. our factory in Peterborough, Ontario.

The Model Number and Serial Number of your Summeraire Furnace must accompany all claims for warranty.



Built Better to Last Longer

Manufactured by
Summerraire Manufacturing
Division of Trent Metals Limited
Peterborough, Ontario
Canada

May 16, 2011
F-SLO80-INS/USMAN-EN-REV23
Specifications and illustrations subject to change
without notice and without incurring obligations.